

FLEX-AUGER® Feed Delivery Systems and Accessories

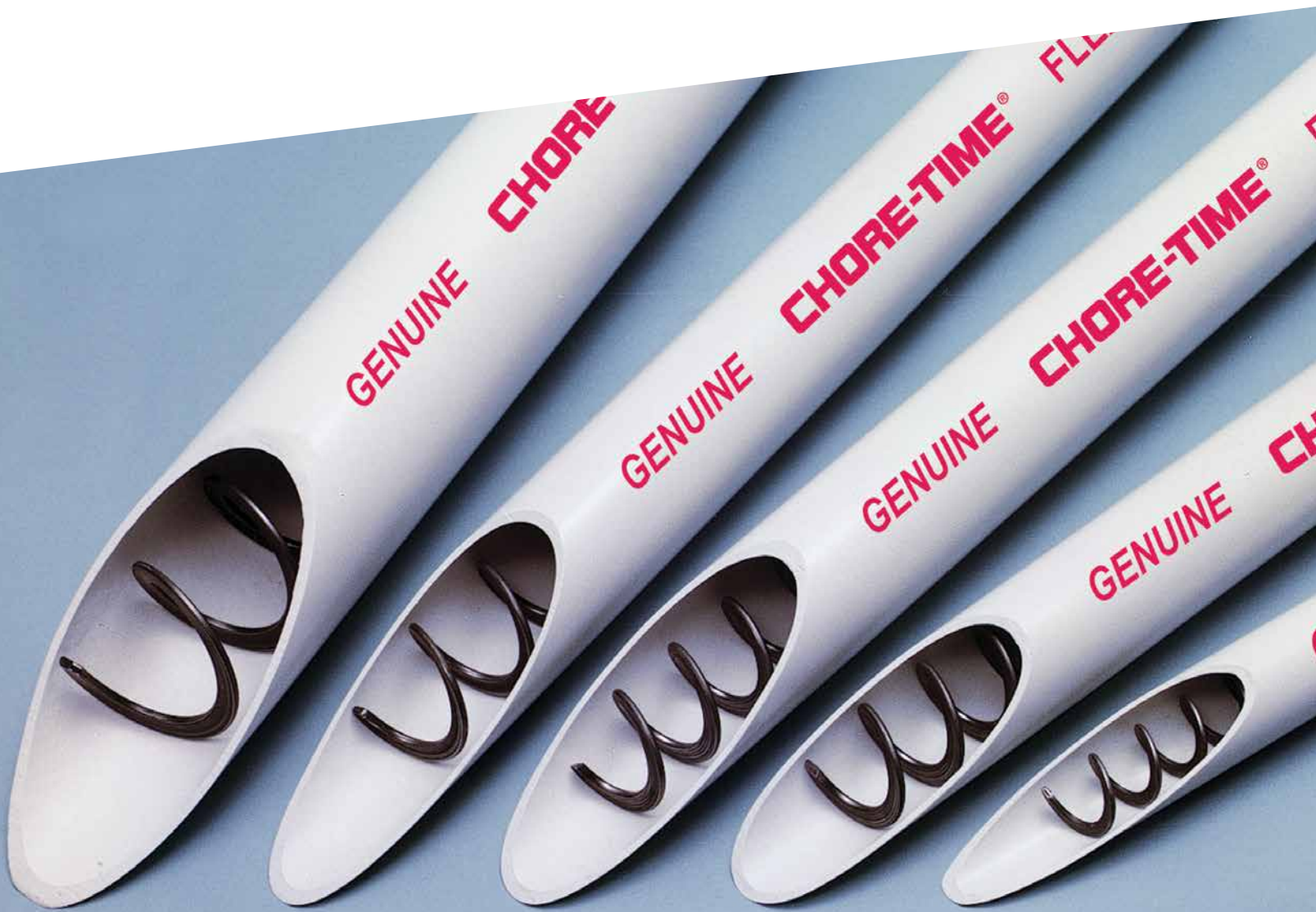

Let's grow together®



Count on Chore-Time for
experience, reliability,
performance and confidence.

The Reliable Original

Often imitated, but never equaled!

- Chore-Time invented the FLEX-AUGER® Coreless Auger Feed Delivery System in 1961. In the years since then, Chore-Time's FLEX-AUGER® System has proven to be the most reliable and best system ever devised to deliver feed.
- Feed conveying capacities from 15 to 250 pounds (6.8 to 110 kg) per minute.

FLEX-AUGER® System Components and Accessories Are Designed for Convenience and Worry-Free Performance



Available in five capacities, Chore-Time's FLEX-AUGER® System features a high-tensile strength spring-like steel auger and specially-compounded ultraviolet- and wear-resistant PVC tubing.

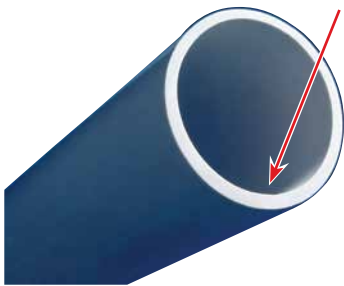

Curved PVC elbows permit Chore-Time's FLEX-AUGER® to move feed up, down, or around corners. Thicker PVC at the inside radius provides a long-lasting wear area.

Highly energy-efficient, extremely long-wearing and trouble-free. That's how FLEX-AUGER® Systems are known around the world.

- Helps optimize feed conversion by keeping feed fresh and reducing waste.
- Choice of conveying rates for a wide variety of feeding applications.
- Fully enclosed system distributes feed accurately and economically.
- Moves feed up, down, on-the-level, or around corners.
- Low power requirements and low maintenance costs.
- System is easily installed in minimal space.
- Designed to be highly energy-efficient, long-wearing and trouble-free.
- 10-year prorated warranty. (See Chore-Time's full written warranty for complete details.)
- Automatic controls and scales are also available.

FLEX-AUGER® Accessories Are Made to Work. Built to Last.®



The power unit features a unique, proven gearhead. The control unit includes a red translucent polycarbonate body and a nearly-clear, side-draw polypropylene funnel.



Upper boot transitions are available in clear or translucent red polycarbonate for easy feed visibility. 30-degree upper boot transitions are also available.

Plastic outlet drop is easy to install with several mounting options.



Chore-Time's Feed Scale is a diagnostic tool to help measure bird performance based on eating rates and habits.

FLEX-AUGER® System Specifications

Feed delivery rate calculated at standard 40 pounds per cubic foot (640 kg per cubic meter) feed density.



Let's grow together®

	Model 75	Model HMC	Model 90 (Standard)	Model 90 (High Speed)	Model 90 (Extra High Speed)	Model 108 (Standard)	Model 108 (High Speed)
Feed Delivery Rate per Minute*	50 pounds (20 kg)	50 pounds (20 kg)	100 pounds (45 kg)	120 pounds (55 kg)	170 pounds (75 kg)	220 pounds (100 kg)	250 pounds (110 kg)
Power Unit RPM	348	348	348	425 (60 Hz only)	584	348	425 (60 Hz only)
Outside Diameter of Tube	3 inches (75 mm)	3.5 inches (90 mm)	3.5 inches (90 mm)	3.5 inches (90 mm)	3.5 inches (90 mm)	Steel – 4.25 inches (108 mm) PVC – 4.5 inches (115 mm)	Steel – 4.25 inches (108 mm) PVC – 4.5 inches (115 mm)
Elbow Radius	5 feet (1.5 meters)	5 feet (1.5 meters)	5 feet (1.5 meters)	5 feet (1.5 meters)	5 feet (1.5 meters)	5 feet (1.5 meters)	5 feet (1.5 meters)
Recommended Motor at Maximum Length	1 HP	1 HP	1 HP	1 HP	1.5 HP	1.5 HP	2 HP
Maximum Length	200 feet (60 m)	150 feet (45 m)	150 feet (45 m)	120 feet (35 m)	120 feet (35 m)	150 feet (45 m)	150 feet (45 m)
Standard Extension**	245 feet (75 m)	185 feet (55 m)	185 feet (55 m)	150 feet (45 m)	N/A	185 feet (55 m)	185 feet (55 m)
Typical Applications	Broiler and turkey production or hog grow and finish houses	Dairy cattle feeding or large particle feeds	Broiler, breeder, turkey or layer houses; or large hog buildings	Broiler, breeder, turkey or layer houses; or large hog buildings	Broiler breeder houses only	Broiler, breeder or layer houses; bin filling, grain moving or stationary mills	Breeder or layer houses; bin filling, grain moving or stationary mills

*Feed delivery rate calculated at standard 40 pounds of feed per cubic foot (640 kg per cubic meter) feed density.

**Standard extensions use extension boot at motor end of first auger, plus additional tube, auger and motor.

NOTE: Where extra feed storage or dual rations are required, use Chore-Time's straight-through tandem system, or 30-degree two-motor tandem system. Tandem systems are available for Models 75, 90, HMC and 108. For each straight-through tandem system (Model 75, HMC, 90 and 108), decrease maximum line length for each power unit by 50 feet (15 m). For Model 90 three-bin, straight-through systems, line length should also be decreased by 50 feet (15 m). FLEX-AUGER® Model 55 also available.

Chore-Time's mechanical and electronic switches provide reliable feed sensing.

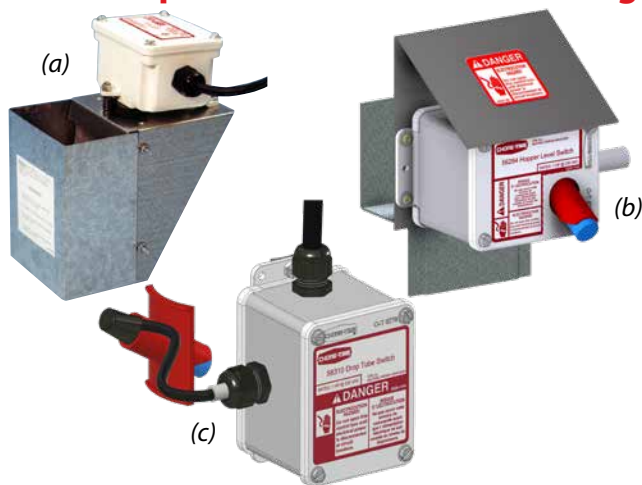

The mechanical Hopper Level Control (a) is used to maintain the feed level in the hoppers for continuous feed supply. The electronic Hopper Level Control (b) and Drop Tube Switch (c) adjust automatically to changes in feed type. A built-in programmable delay prevents short-cycling.

Chore-Time offers a variety of accurate, reliable, easy-to-use controls from more advanced multi-function units to basic, single-function controls.



Multi-function CHORE-TRONICS® 3 Control

Chore-Time's Auger Timer (d) can be used to prevent the auger system from running longer than a pre-set time between three and 100 minutes. The timer prevents the system from running empty for long periods of time. For added protection, the system requires a manual re-set after activation.

Chore-Time's Genuine FLEX-AUGER® Coreless Auger Feed Delivery System

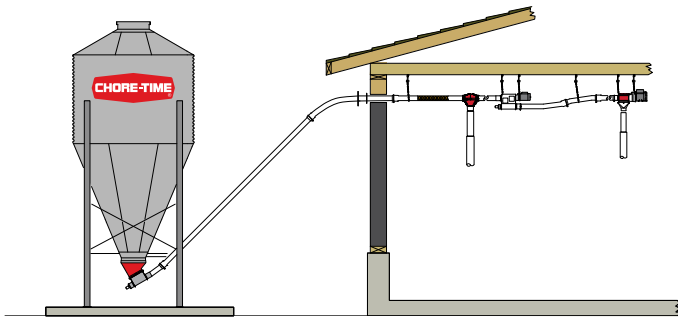

Manual Boot Slide Actuator for Straight-Out or 30-Degree Boots

The **Manual Boot Slide Actuator** from Chore-Time helps producers easily open and close the feed bin boot slide without having to physically crawl under, around, or through the feed bin's leg and hopper support bracing system.

- Telescoping handle extends from 5 to 8 feet (1.5 to 2.5 m) to allow the actuator to be operated from outside the feed bin's leg and brace area.
- Easy-to-operate rack and pinion design quickly opens or closes boot slides in just over two turns.
- Opener can be installed for either right- or left-hand operation.
- Single and twin-boot versions available.

Chore-Time's Feed Screener Chore-Time's Single and Twin Inline Screeners are available for the FLEX-AUGER® Model 90 and 108.

Based on standard models with 348 revolutions per minute.

- The maximum capacity for the Model 90 is 100 pounds (45 kg) per minute per line.*
- For the Model 108, the capacity is approximately 220 pounds (100 kg) per minute per line.
- There is the possibility to use the inline screener with the Model 108 (high speed) with 425 revolutions per minute.
- For the Model 108 (high speed) 425 RPM, the capacity is 250 pounds (110 kg) per minute per line.

Twin Straight Out or Twin Stackable Control Units for feed blending applications

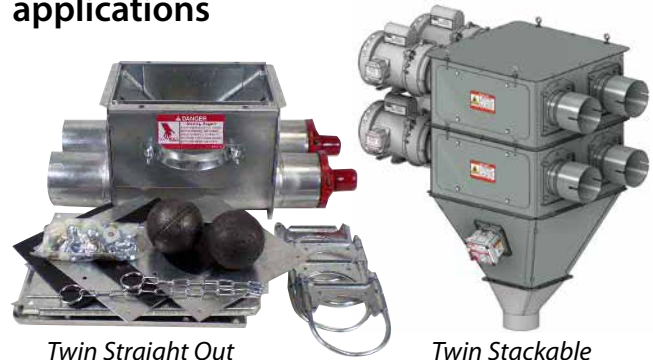

Twin Straight Out

Twin Stackable

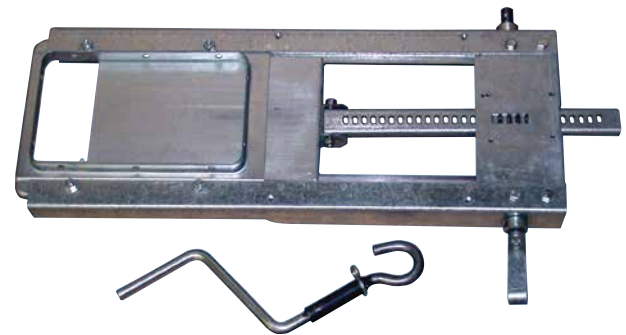

*Manual Boot Slide Actuator
(Note: Handle has been shortened for photo purposes.)*



Dual inline Screener (Single Inline screener also available.)



Let's grow together®

www.choretime.com

Chore-Time is a division of CTB, Inc.
A Berkshire Hathaway Company

Find your authorized independent distributor at choretime.com/distributor

Chore-Time
Milford, Indiana USA
info@choretime.com

Chore-Time Europe Sp. z o.o.
Strykowo, Poland
info@choretime.pl

Chore-Time Europe B.V.
Panningen, Netherlands
info@choretime.nl

Volito B.V.
Ede, Netherlands
info@choretime.nl